

SINEAX A 210 / A 220

Multifunctional Power Monitor

63 measured quantities

8 energy meters

5 average power values P, Q, S each

Application

The A 210/A 220 power measuring instrument is suitable for control panel mounting and measures all the important measurands in 3-phase and single-phase systems.

It displays the measurands with a high contrast 14 mm high LED display. The instrument is also suitable for measurements in high and middle voltage systems because of the freely programmable factors for the current and voltage transformers.

It replaces a large number of analog instruments and delivers high-accuracy values.

The basic execution is an instrument with 2 S0-outputs, which can be programmed as pulse or limit outputs. Extension modules increase the functionality and flexibility. The EMMOD 201 module has an RS232/RS485 interface and supports data exchange with a control system via MODBUS RTU. Memory and a digital input (switching between high and low tariffs) for monitoring, or the storage of average power values (load profile) complete the functionality. The user-friendly *A200plus* software supports parameter setting and reading the measured values.

The EMMOD202 has 2 galvanically isolated analog outputs. Any of the important input measurements can be assigned to the 4 - 20 or 0 - 20 mA signal, and it is possible to program an inverted characteristic.

EMMOD203 users can communicate with the Ethernet and Internet worlds with the MODBUS protocol over TCP/IP and HTTP. In addition, the module has an extensive memory, which supports backed up recordings for up to one year. The data are recorded with an exact time stamp, which is given by an internal, battery backed up clock.

The EMMOD204 supplements the functionality as well as the flexibility of the basic device by an Profibus-DP interface.

All the modules can be upgraded by simply plugging in the extension module without having to open the power monitoring instrument. A separate power supply is not required.

Features

- Measurement of current, voltage, active, reactive and apparent power, active and reactive energy, neutral conductor current, power factor and frequency
- 4 meters for active power: Incoming/outgoing with high/low tariff
- 4 meters for reactive power: Inductive/capacitive with high/low tariff
- 5 values each for active, reactive and apparent power averages with programmable interval times



- Two S0-outputs for pulse or limit values
- Dimensions: SINEAX A 210: 96 x 96 x 46 mm
SINEAX A 220: 144 x 144 x 46 mm
- Programmable conversion factors
- Flexible power supply with an AC/DC wide-range power supply unit
- Electrically isolated current inputs (1 A or 5 A)
- Upgrade extension modules with RS232/RS485 interface, load profile memory, MODBUS, synchronizing input, analog outputs, Ethernet or Profibus-DP
- Accurate measured values for U, I \leq 0.5%, F \leq 0.02 Hz, others 1%
- Storage of minimum and maximum values
- Measurement in single-phase systems, 3-wire and 4-wire systems in 4 quadrant operation

Benefits

- High functionality (63 measurand values) in a compact form (depth 46 mm)
- Therefore low costs for purchase, engineering and installation
- Safe 3-way galvanic isolation between all circuits and between the 3 current inputs
- Large LED display that can be read from a distance, especially suitable for badly lit rooms
- Robust front (IP 66) for tough industrial applications
- Storage of all counter values, the min./max. values, the display mode and the programmed data on failure of the power supply

SINEAX A 210 / A 220

Multifunctional Power Monitor

Version	Order No.	
	A 210	A 220
500 V / 5 A, power supply 85 to 253 V AC/DC	149 783	152 546
500 V / 5 A, power supply 20 to 70 V AC/DC	150 300	152 554
500 V / 5 A, power supply 85 to 253 V AC/DC, with test certificate	150 318	152 562
500 V / 5 A, power supply 20 to 70 V AC/DC, with test certificate	150 326	152 570
500 V / 1 A, power supply 85 to 253 V AC/DC	152 447	152 588
500 V / 1 A, power supply 20 to 70 V AC/DC	152 702	152 736
500 V / 1 A, power supply 85 to 253 V AC/DC, with test certificate	152 710	152 752
500 V / 1 A, power supply 20 to 70 V AC/DC, with test certificate	152 728	152 744
500 V / 5 A, power supply 85 to 253 V AC/DC	158 635	158 643

Each input is sampled 32 times per cycle. This allows measurements to be made including up to the 15th harmonic.

The calculation of the measurands is made in accordance with DIN 40 110 part 1 and part 2, however in 4-quadrant operation.

In the figures at this data sheet only SINEAX A 210 is shown. Display and operating are identical with the A 220.

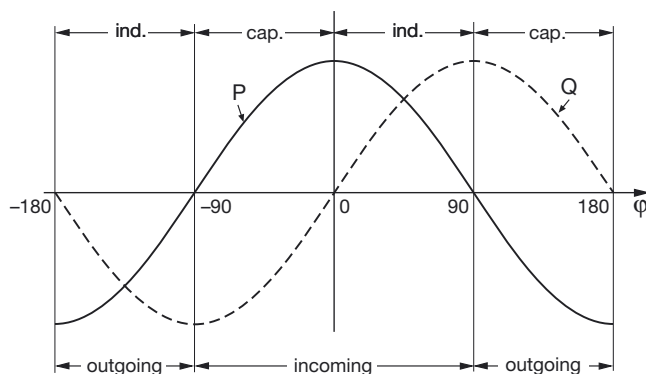

Function

The instrument measures the currents I1, I2, I3 and the voltages U1, U2, U3, the frequency, and the phase angles between the individual currents and voltages. All the other measurands are calculated from these. The measurements are made internally via integrated current transformers. Therefore it is possible to make direct connections without an external transformer.

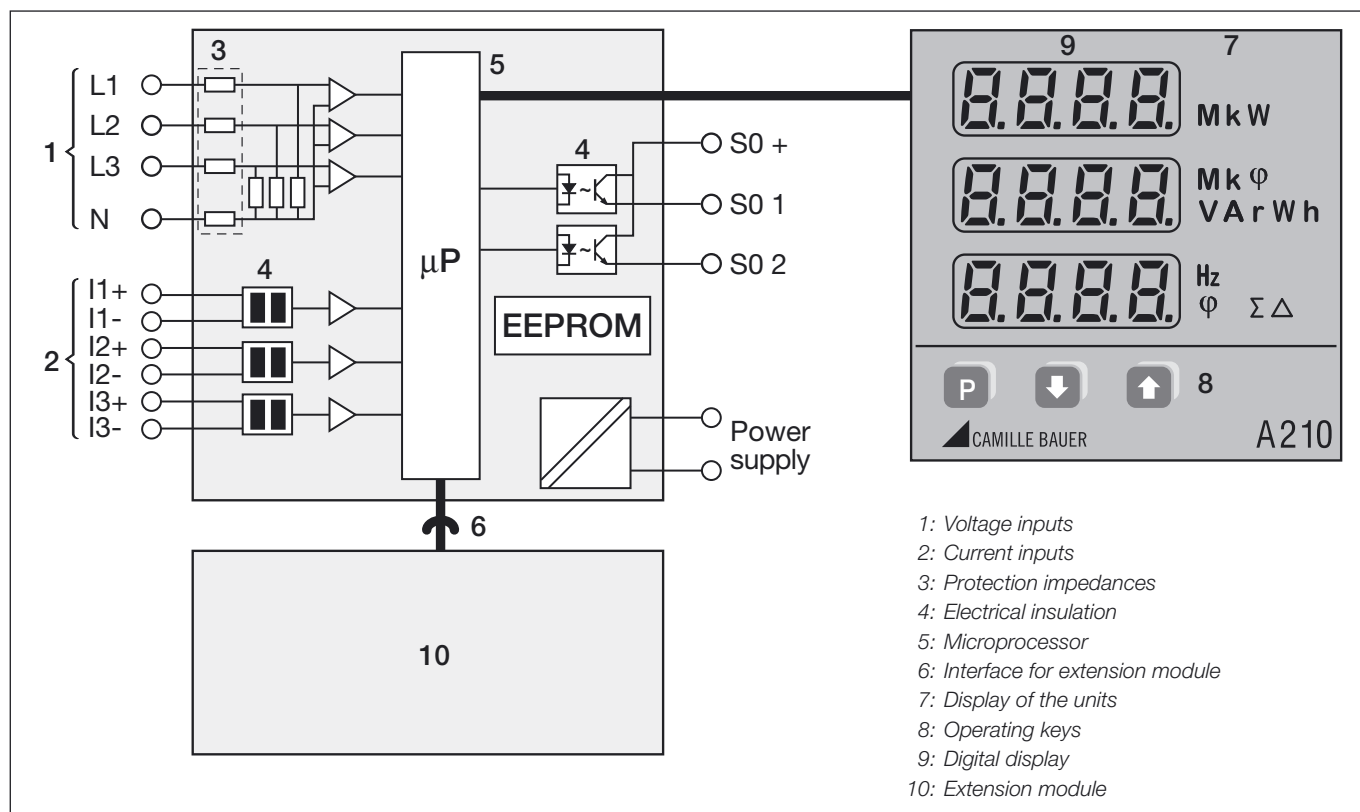

Fig. 1. Block diagram.

SINEAX A 210 / A 220

Multifunctional Power Monitor

Technical data

System/application

Single-phase, 3-wire balanced or unbalanced, 4-wire balanced or unbalanced, 4-quadrant operation

Measurements available

Measured quantities	Measuring path	max	min
Voltage	1-N, 2-N, 3-N	●	●
Voltage	1-2, 2-3, 3-1	●	●
Current	1, 2, 3, N	●	
Current I_{avg} (bimetal -15 min/ slave pointer)	1, 2, 3	●	
Active power P	1, 2, 3, Σ	●	
Reactive power Q	1, 2, 3, Σ	●	
Apparent power S	1, 2, 3, Σ	●	
$\cos\phi$ (4-quadrant display)	1, 2, 3, Σ		
$\cos\phi$ inductive min.	1, 2, 3		●
$\cos\phi$ capacitive min.	1, 2, 3		●
Frequency	U, I		
P-meter incoming/outgoing (HT/NT)	Σ		
Q-meter ind./cap. (HT/NT)	Σ		
5 active power interval value	Σ		
5 reactive power interval values	Σ		
5 apparent power interval values	Σ		

Programmable values (basic unit)

Trip points, pulse rate, transformer ratio, type of system, interval time for average power values.

Programming can be locked with a jumper at the back of the instrument.

However, the limit values can still be changed.

All min. and max. values and the counter values can be reset. The resetting of the counter values can also be blocked with the above mentioned jumper.

All the measurands, the selected display, the counter values and the programmed data are kept on a power failure.

Factory default

Brightness:	(mid setting)
Limit value / S01:	Off
Limit value / S02:	Off
Transformer ratio:	1 : 1
Jumper:	Not in the LOCK position
Connecting mode:	4-wire asymmetric load
Synchronizing interval:	15 min.

Applicable regulations and standards

IEC 1010 resp. EN 61 010 Safety regulations for electrical measuring, control and laboratory equipment

EN 60 529	Protection types by case
DIN 43 864	Current interface for the transmission of impulses between impulse encoder counter and tariff meter (S0 output)
DIN 40 110	AC quantities
IEC/EN 61326-1 IEC/EN 61326/A1	Electrical equipment for measurement, control and laboratory use, EMC requirements
EN 60 688	Electrical measuring transducers for converting AC electrical variables into analogue and digital signals
IEC 68-2-1/-2/-3/-6/-27 resp. EN 60 068-2-1/-2/-3/-6/-27	Ambient tests -1 Cold, -2 Dry heat, -3 Damp heat, -6 Vibration, -27 Shock

Measuring inputs

Nominal frequency:	50, 60 Hz
Nominal input voltage:	Phase-phase: 500 V Phase-N: 290 V
Nominal input current:	5 A or 1 A
Waveform:	Sine
Own consumption:	Current circuit: $\leq I^2 \cdot 0.01 \Omega$ Voltage circuit: $\leq \frac{U_{LN}^2}{300 \text{ k}\Omega}$

Continuous thermal rating of inputs

10 A at 346 V in single-phase AC system

10 A at 600 V in three-phase system

Short-time thermal rating of inputs

Input variable	Number of inputs	Duration of overload	Interval between two overloads
557 V LN	10	1 s	10 s
100 A	10	1 s	100 s
100 A	5	3 s	5 min.

Measuring range

U, I, S:	$\leq 120\%$ of nominal value
P, Q:	$\leq \pm 120\%$ of nominal value
F:	45 to 65 Hz
$\cos\phi$:	± 1
Overload indicator:	oL

The frequency is measured from the current or voltage. The voltage has priority.

SINEAX A 210 / A 220

Multifunctional Power Monitor

Pulse/limit value outputs

Depending on the function selected, the two digital outputs can be used either as pulse outputs for active and reactive energy or as limit signals.

The outputs are passive, and are galvanically isolated from all the other circuits by opto-couplers. They are suitable to drive tariff devices (S0-standard DIN 43 864) or 24 V-relais.

$U_{ext} \leq 40 \text{ V DC}$ (OFF: leakage current $\leq 0.1 \text{ mA}$)
 $I_L \leq 150 \text{ mA}$ (ON: terminal voltage $\leq 1.2 \text{ V}$)

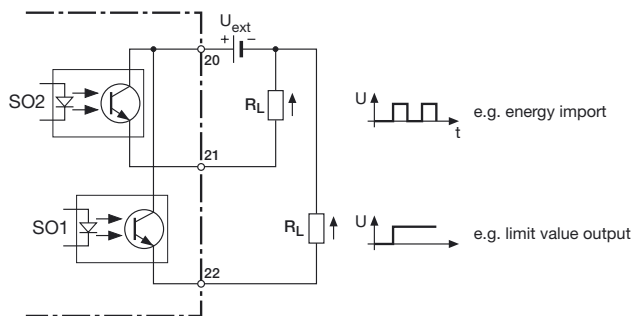

Limit value outputs:

the limits can be associated with any measurand. Depending on the type of connection an OR or an AND function is possible for the following values.

3-wire unbalanced load: $U_{12}/U_{23}/U_{31}$, $I_1/I_2/I_3$, $I_{avg1}/I_{avg2}/I_{avg3}$

4-wire unbalanced load: $U_1/U_2/U_3$, $U_{12}/U_{23}/U_{31}$, $I_1/I_2/I_3$, $I_{avg1}/I_{avg2}/I_{avg3}$, $P_1/P_2/P_3$, $Q_1/Q_2/Q_3$, $S_1/S_2/S_3$, $PF_1/PF_2/PF_3$

Alarm ON: OR function of the phase measurands
 Alarm OFF: AND function of the phase measurands
 Delay time: Fixed at 1 s (cannot be modified)

Pulse outputs:

The reactive and active energy can be read out at the pulse outputs in the form of standard S0 pulses for the driving of electronic and electromechanical counting mechanisms.

The pulse rate is programmable:

1 ... 5000 Imp./Wh ... GWh resp. 1 ... 5000 Imp/varh ... Gvarh

The duration of the pulses cannot be programmed and also cannot be changed by hardware means.

Pulse duration: > 100 ms

For systems with external transformers, the pulses are for the primary energy data.

Power supply

DC, AC power pack 45 to 400 Hz

85 to 253 V AC/DC or

20 to 70 V AC/DC

Power consumption: < 3 VA (without interface module)

Display

14 mm LED digital display; adjustable brightness

3 digits with sign, frequency: 4 digits, energy: 8 digits

Colour: red

Zero value suppression

PF resp. $\cos\phi$:

Display ---, if $S_x < 0.2\% S_{nenn}$

Currents:

Display 0, if $I_x < 0.1\% I_{nenn}$

Example of the display for 4-quadrant measurements

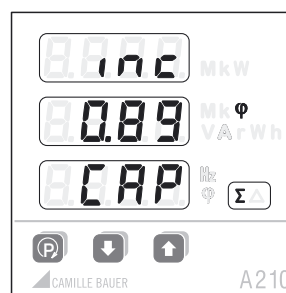

System

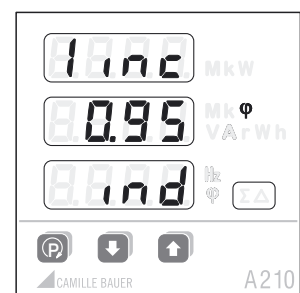

Phase 1

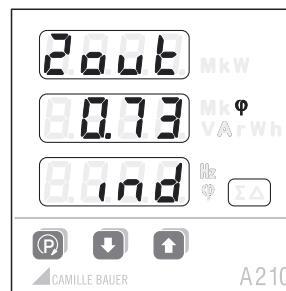

Phase 2

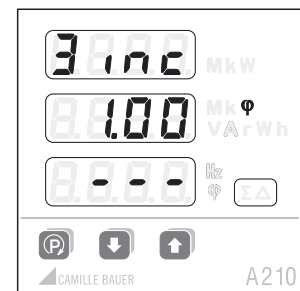

Phase 3

ind inductive
cap capacitive

inc incoming
out outgoing

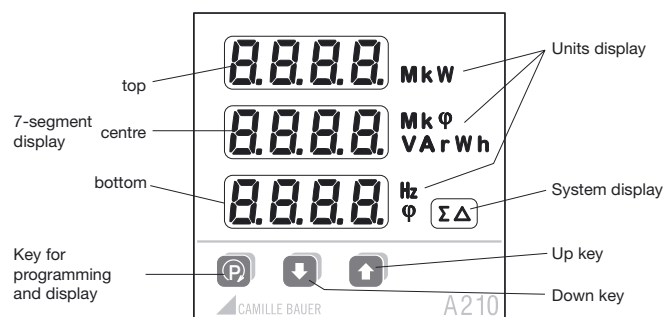

SINEAX A 210 / A 220

Multifunctional Power Monitor

Display levels: e.g. 4-wire unbalanced load

		a	b	c	d	e	f
 	1	U1 U2 U3	U1 _{max.} U2 _{max.} U3 _{max.}	U1 _{min.} U2 _{min.} U3 _{min.}	U12 U23 U31	U12 _{max.} U23 _{max.} U31 _{max.}	U12 _{min.} U23 _{min.} U31 _{min.}
	2	I1 I2 I3	I1 _{max.} I2 _{max.} I3 _{max.}	I1 _{avg.} I2 _{avg.} I3 _{avg.}	I1 _{avgmax.} I2 _{avgmax.} I3 _{avgmax.}	IN	IN _{max.}
	3	P1 P2 P3	P1 _{max.} P2 _{max.} P3 _{max.}	P	P _{max.}		
	4	Q1 Q2 Q3	Q1 _{max.} Q2 _{max.} Q3 _{max.}	Q	Q _{max.}		
	5	S1 S2 S3	S1 _{max.} S2 _{max.} S3 _{max.}	S	S _{max.}		
	6	PF1	PF2	PF3	PF	PF _{minind}	PF _{mincap}
	7	F					
	8	EPinc HT ¹	EP inc LT ²	EP out HT ¹	EP out LT ²		
	9	EQ ind HT ¹	EQ ind LT ²	EQ cap HT ¹	EQ cap LT ²		
	10	P Q PF	P S F				
	11	Pint0	Pint1	Pint2	Pint3	Pint4	
	12	Qint0	Qint1	Qint2	Qint3	Qint4	
	13	Sint0	Sint1	Sint2	Sint3	Sint4	

¹ HT = High tariff

² LT = Low tariff

Safety

Protection class: II (voltage inputs with protection impedances)

Measuring category: III

Pollution degree: 2

Measurement voltage: 300 V

Test voltage: Between current inputs, power supply, digital outputs, terminals of the plugged-in module: 3700 V / 50 Hz / 1 min.

On voltage inputs:
4.25 kV 1.2/50 µs

Module connections: The pin rail at the back is connected to the voltage inputs via a protection impedance. Only the permitted modules can be plugged-in!

Enclosure protection: Front IP 66, terminals IP 20

Inputs, outputs and power supply are electrically isolated. The current inputs are electrically isolated from each other.

Accuracy data

Reference conditions acc. to IEC 688 resp. EN 60 688

Sine 50 - 60 Hz, 15 - 30°C, application group II

Measurement accuracy (related to nominal value)

Current, voltage	± 0.5%
Power	± 1.0%
Power factor	± 1.0%
Energy	± 1.0%
Frequency	± 0.02 Hz (abs.)

Mechanic

Dimensions	A 210:	96 x 96 x 46 mm; Panel cutout 92 ^{+0.8} x 92 ^{+0.8} mm
	A 220:	144 x 144 x 46 mm; Panel cutout 138 ⁺¹ x 138 ⁺¹ mm

Terminals:

Inputs	Screw terminals
	Wire gauge single wire: 0.5 - 2.5 mm ² Wire gauge fine wire: 0.5 - 1.5 mm ²
Power supply, outputs	Clamps
	Wire gauge single and fine wire: 0.5 - 1.5 mm ²

Housing material: ABS
flammability class V-0 acc. to UL 94, self-extinguishing, non-dripping, free of halogen

Weight: 250 g at A 210 resp.
300 g at A 220

Mounting: For control panel mounting

Environmental conditions

Operating temperature: - 10 to + 55 °C

Storage temperature: - 25 to + 70 °C

Humidity relative: ≤ 75%

Altitude: 2000 m max.

Indoor use statement

SINEAX A 210 / A 220

Multifunctional Power Monitor

Electrical connections

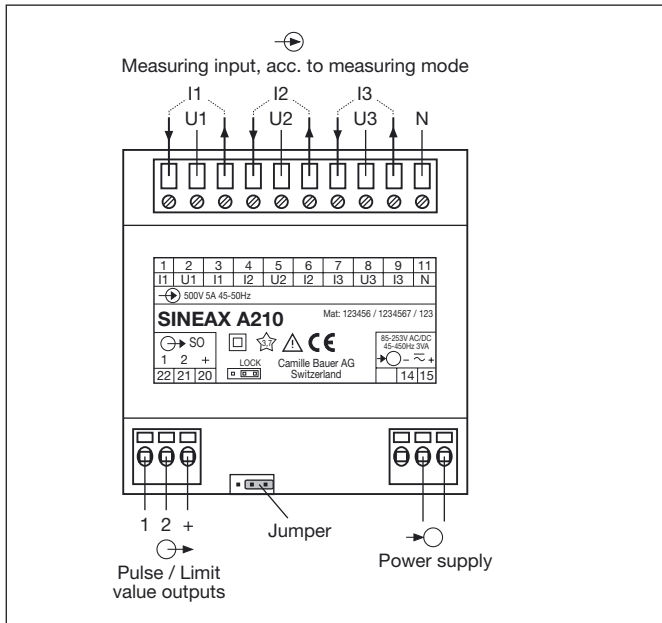

Connecting modes

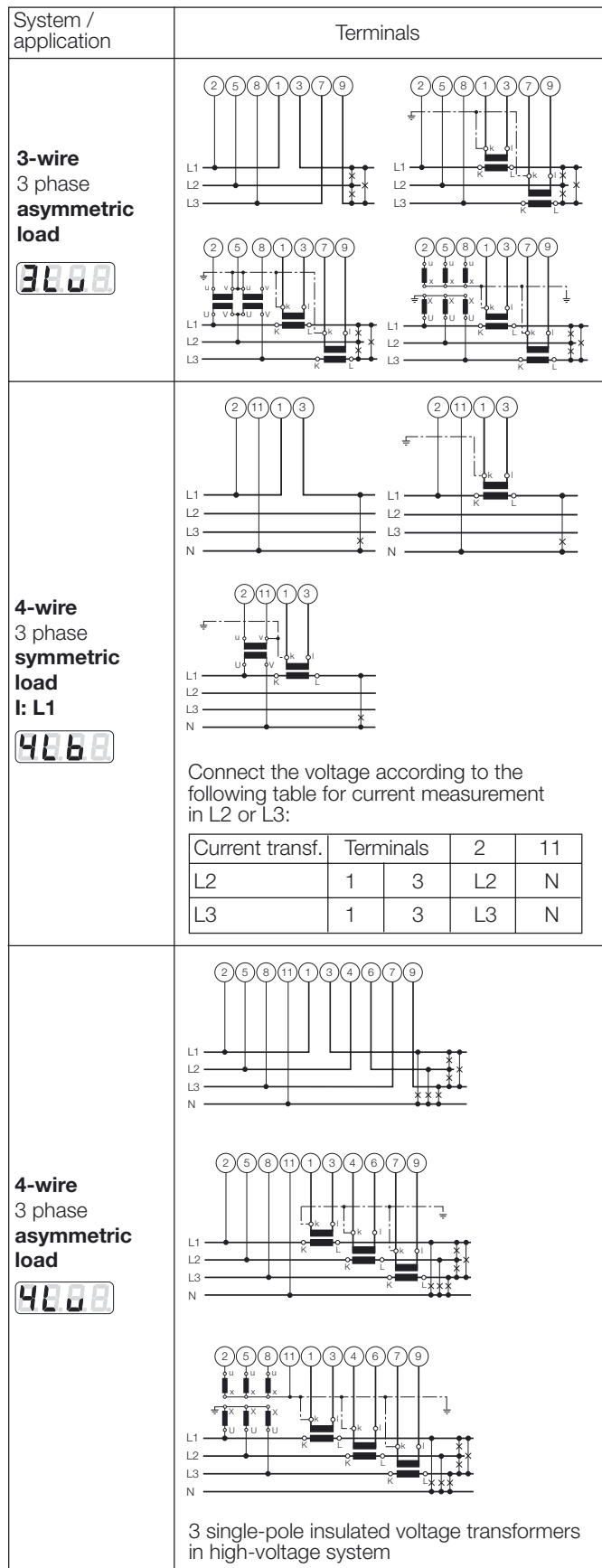
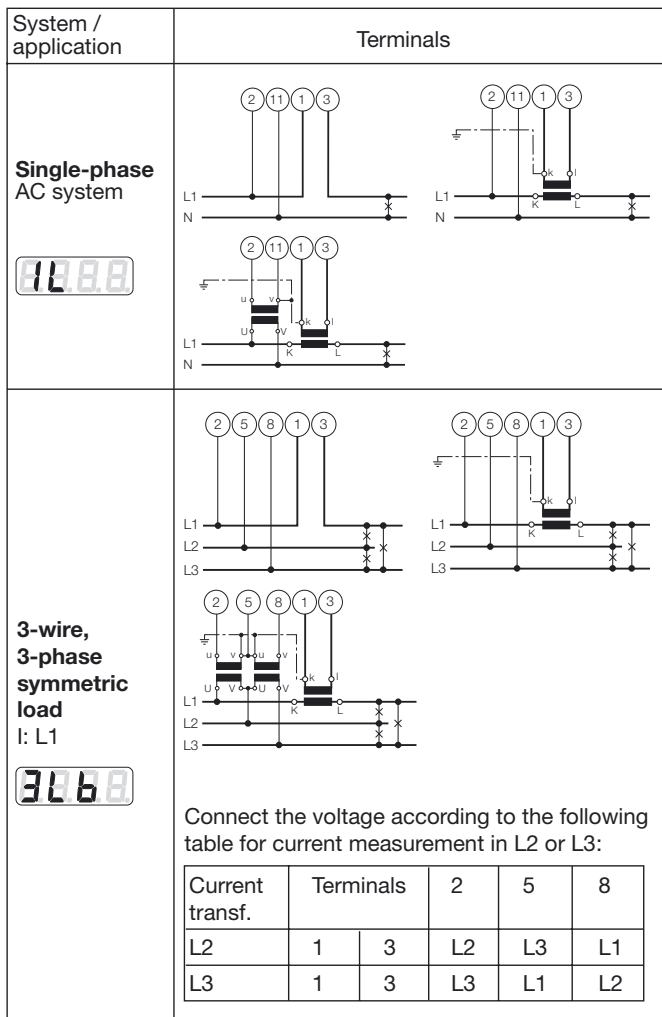

SINEAX A 210 / A 220

Multifunctional Power Monitor

Maintenance

No maintenance is required.

Dimensional drawings

SINEAX A 210

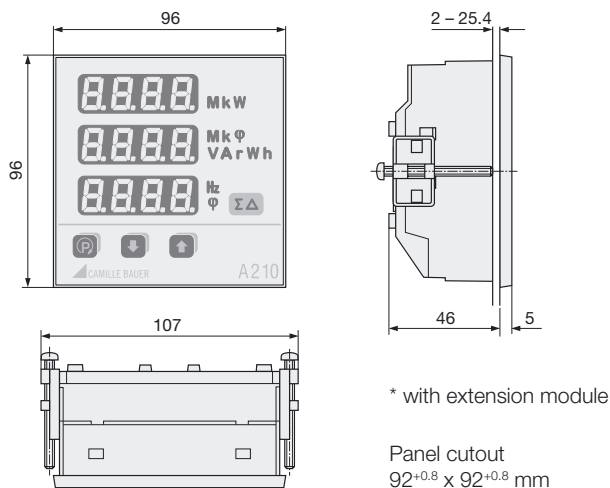

SINEAX A 220

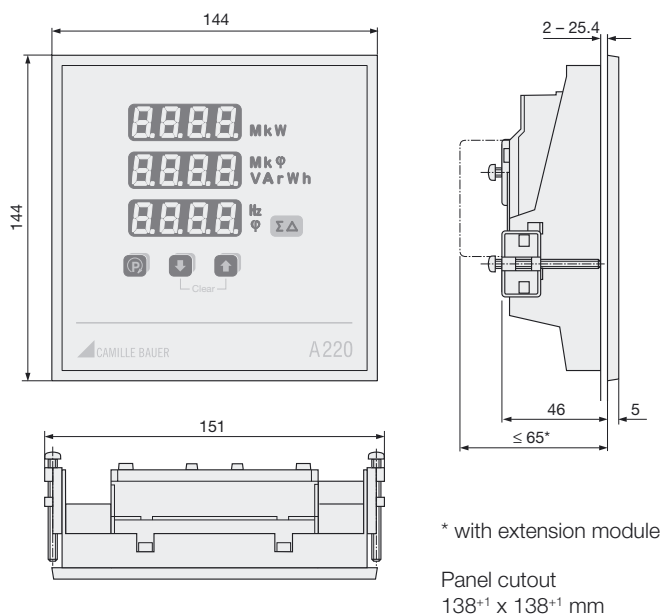

Scope of supply

Basic unit without extension module

Operating Instructions in German, French and English
Fixing clamp

Measuring protocol at instruments with order No.:
A 210: 150 318, 150 326, 152 710 and 152 728
A 220: 152 562, 152 570, 152 752 and 152 744

Accessories SINEAX A 210/A 220

Description	Article No.
Operating Instructions in German, French and English	151 118
Top-hat rail adapter (A 210 only)	154 055
Extension module EMMOD 201 Interface/MODBUS RTU/data logger	150 285
Extension module EMMOD 202 2 analog outputs	155 574
Extension module EMMOD 203 Ethernet, 2 MB memory, real-time clock	155 582
Extension module EMMOD 204 Profibus-DP	158 510

Extension module EMMOD 201

Communication

Interface:	RS232/RS485 switchable
Protocol:	MODBUS RTU for SCADA
Digital input:	Synchronizing input for average power values or switching between high/low tariff for the energy counters
Bus interface address:	1 to 247
Baudrate:	1200, 2400, 4800, 9600, 19.2 k
Parity check:	no, even, odd, space

Recording average power values

Values that can be recorded:	Pint: active power average value with sign (incoming + / outgoing -) Qint: reactive power average value (inductive + / capacitive +)
Amount of data at 15 min intervals:	1 value (Pint or Qint) = 166 days 2 values (Pint and Qint) = 83 days

Accessories EMMOD 201 (not included in scope of supply)

Description	Article No.
Software A200plus *)	146 557
Interface adapter cable	152 603
Extension cable sub-D 9pol. 2 m	980 179

All dimensions in mm.

SINEAX A 210 / A 220

Multifunctional Power Monitor

Dimensional drawing

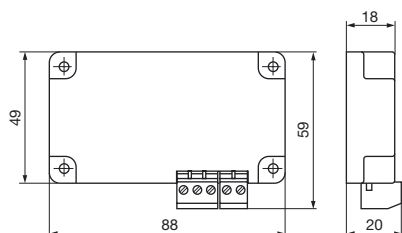

Extension module EMMOD 202

Input:	U, I, Iavg, In, P, Q, S, F, cosφ
Output:	0 - 20 mA, 4 - 20 mA, inverting
Limitation:	0/3.7 mA resp. 21 mA
Burden voltage:	8 V
Accuracy:	0.1% (without A2..)
Number of channels:	2 (electrically isolated)

Dimensional drawing

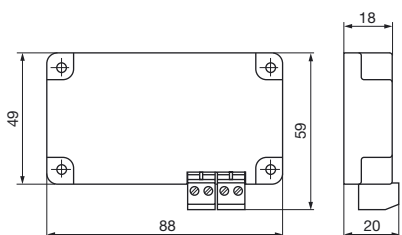

Extension module EMMOD 203

Protocols:	MODBUS over TCP/IP, HTTP
Real-time clock:	Battery backup, synchronized via LAN or external (e.g. 230 V/50 Hz)
Memory:	Up to one year with time stamp

Connections

Ethernet RJ45 port:	10/100 base Tx
Tariff switching:	Plug-in screw terminals
Synchronizing input:	Plug-in screw terminals
Synchronizing input:	5 V – 300 V AC, 1 – 500 Hz
Tariff switching:	5 V – 300 V AC/DC

Dimensional drawing

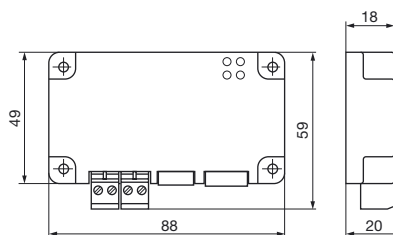

Accessories EMMOD 203 (not included in scope of supply)

Description	Article No.
Software A200plus *)	146 557

*) Download free of charge under <http://www.camillebauer.com>

Extension module EMMOD 204

Interface:	Profibus-DP 9-pin D-sub socket EIA RS485 standard 15 kV ESD protection
Baudrate:	Autom. recognition, 9600 bit/s ... 12 Mbit/s
Type:	DPV0, SPC4-2 Repeater_Ctrl_Sig (TTL)
Address:	126 (0 - 125) Set_Slave_Add_Supp

Dimensional drawing

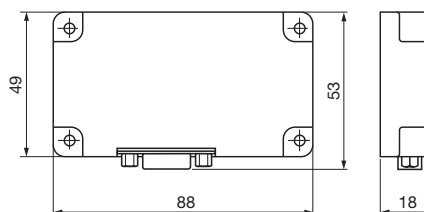

Accessories EMMOD 204 (not included in scope of supply)

Description	Article No.
Device Master File (DMF) *)	150 764

*) Download free of charge under <http://www.camillebauer.com>