

GMT220 Series Carbon Dioxide Transmitters for Industrial Applications



The GMT220 transmitters withstand harsh and humid environments.

The Vaisala CARBOCAP® Carbon Dioxide Transmitter Series GMT220 is designed to measure carbon dioxide in harsh and humid environments. The housing is dust- and waterproof to IP65 standards. The materials have been chosen for good corrosion resistance.

High-end measurement technology

The GMT220 series transmitters incorporate the advanced Vaisala CARBOCAP® Sensor. The patented sensor has unique reference measurement capabilities. Its critical parts are made of silicon; this gives the sensor outstanding stability over both time and temperature. By lengthening the time between calibration intervals, the user saves both time and money.

Optimal measurement range for each application

The user has a choice of measurement ranges up to 20 % CO₂; the GMT221 for higher concentrations of CO₂ and the GMT222 for lower concentrations of

CO₂. The transmitter can be connected to various measurement systems. In addition to standard analog, voltage and current outputs, there are also two configurable relay outputs. Activated relays are indicated by LED lights on the cover.

Interchangeable probes

The GMT220 probes are truly interchangeable. They can be removed and reattached or replaced at any time – without the need for calibration and adjustment. The probes can be attached directly to the transmitter body or, when used with a cable, installed remotely into hard-to-reach places or areas with dangerously high levels of CO₂.

Simple installation

A separate mounting plate makes installing the transmitter easy - simply attach the mounting plate to the wall and lock the transmitter body in place.

Features/Benefits

- Incorporates Vaisala CARBOCAP® - the silicon-based NDIR sensor
- IP65 protected against dust and spray water
- Several measurement ranges
- Easy installation
- Interchangeable probes – easy maintenance

Applications

- Horticulture and fruit storage
- Greenhouses and mushroom farming
- Safety alarming and leakage monitoring
- Demand controlled ventilation in harsh environments

Easy field maintenance

The interchangeability of the GMT220 transmitter's probes truly facilitates field maintenance.

Probes can be replaced by newly calibrated ones, or by reference probes for calibration purposes. This minimizes downtime. The end user can carry out field maintenance without any additional equipment or heavy and expensive calibration gas bottles. Probes that have been replaced can be sent to Vaisala for recalibration.

The Vaisala CARBOCAP® Hand-Held Carbon Dioxide Meter GM70 can be used for field verification and/or calibration.



Technical Data

Performance

Measurement Ranges	
GMT221	0...2 % 0...3 % 0...5 % 0...10 % 0...20 %
GMT222	0...2000 ppm 0...3000 ppm 0...5000 ppm 0...7000 ppm 0...10 000 ppm
Accuracy (including repeatability, non-linearity and calibration uncertainty) at 25 °C and 1013 hPa	
GMT221	±(1.5% of range + 2% of reading) (applies for concentrations above 2% of full scale)
GMT222	±(1.5% of range + 2% of reading)
Temperature dependence, typical	-0.3 % of reading / °C
Pressure dependence, typical	+0.15 % of reading/hPa
Long-term stability	<±5 %FS/2 years
Response time (63 %)	
GMT221	20 seconds
GMT222	30 seconds
Warm-up time	30 seconds, 15 minute full specifications

Inputs and outputs

Outputs	0...20 or 4...20 mA and 0...10 V
Resolution of analog outputs	12 bits
Recommended external load:	
current output	max. 400 Ohm
voltage output	min. 1 kOhm
Two pre- or user-defined relay outputs	
Relay contacts	max. 30VAC/60VDC, 0.5A
Operating voltage	nominal 24 VAC/DC
Power consumption	<4 W

Operating environment

Operating temperature	-20...+60 °C
with display	0...+50 °C
Storage temperature	-30...+70 °C
Humidity	0...100 %RH, non-condensing
Electromagnetic compatibility	EN61326-1, Generic Environment

Mechanics

Housing material	
transmitter body	ABS plastic
probe	PC plastic
Housing classification	IP65
Weight:	
GMT221	max. 280 g
GMT222	max. 300 g
Probe cable length	2 m and 10 m (optional)

Accessories

Spare probe	GMP221, GMP222 (use the order form to define measurement range etc.)
Clips (2 pcs) for attaching the probe	25245GM
Mounting flange for the probe	GM45156
Probe cables	
2 m	25665GMSP
10 m	210848GMSP
Calibration kit for interchangeable probes	GMK220
Serial COM adapter	19040GM
Chamber for pump-aspirated sampling systems	26150GM

Dimensions

Dimensions in mm (inches)

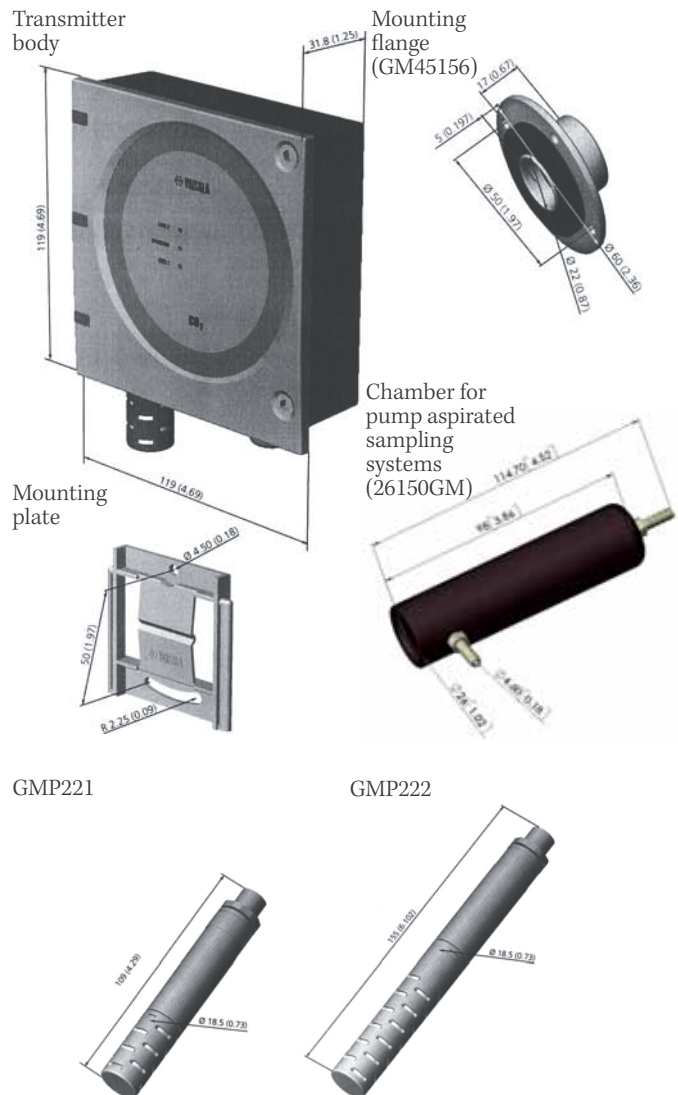

CARBONCAP® is a registered trademark of Vaisala.
 Specifications subject to change without prior notice.
 ©Vaisala Oyj

