

DMT340 Series Dewpoint and Temperature Transmitters for Low Dewpoint Applications



The DMT340 transmitter family has the solution for demanding industrial dewpoint measurements.

The Vaisala DRYCAP® Dewpoint and Temperature Transmitter Series DMT340 is designed for industrial low humidity applications. Typical applications include compressed air drying and metal treatment. The device is very reliable, easy to use and economical to maintain.

Stability in low dewpoints

The Vaisala DRYCAP® Sensor is immune to particulate contamination, water condensation, oil vapor and most chemicals. Since the sensor withstands condensation, its performance is unmatched for low dewpoint applications that experience water spikes in the process. The sensor recovers rapidly from contact with free water.

Patented auto-calibration

The stability of the DMT340 is due to the unique auto-calibration function, patented by Vaisala. The auto-calibration makes the transmitter perform a calibration and adjustment by itself while the measured process is running. If the measurement accuracy is not confirmed, corrections are made automatically. The procedure is so quick and corrections are so minor that it will go unnoticed. This ensures low



The display shows measurement trends, real time data and history.

maintenance and high performance. To continue performance at the highest level, the transmitter can be sent to Vaisala for a NIST traceable calibration. Calibration intervals depend on the application; in normal conditions, a NIST traceable calibration in every two years is recommended.

Graphical measurement trend and history display

The DMT340 can be ordered with a large numerical and graphical display with a multilingual menu. It allows the user to monitor measurement trends and one-year history. The optional data logger with real-time clock makes it possible to generate more than four years of measured history and zoom in on any desired time or time frame.

Features/Benefits

- Measures dewpoints from -60 °C to +80 °C (-76 ... +176 °F) with the accuracy of ±2 °C (±3.6 °F)
- Vaisala DRYCAP® Sensor provides accurate, reliable measurement with excellent long-term stability and fast response
- Withstands condensation
- Unique auto-calibration feature
- Optional alarm relays, local display and mains power supply module
- Compatible with Vaisala DRYCAP® Hand-Held Dewpoint Meter DM70
- NIST traceable (certificate included)
- 3 analog outputs and a serial interface, WLAN/LAN

The display alarm allows tracking of any measured parameter, with a freely configurable low and high limit.

Versatile outputs and (wireless) data collection

The DMT340 can be connected to a network with an optional (W)LAN interface, which enables a (wireless) Ethernet connection.

For serial interface also the USB connection, RS232 and RS485 can be used. Additionally an alarm relay option is available.

The transmitter can have up to three analog outputs. Galvanic isolation of supply power and analog outputs are also offered.

The recorded measurement data can be viewed on the display or transferred to a PC with Microsoft Windows® software.

Easy installation

The DMT340 has a variety of features to choose from.

Units are delivered installation-ready.



The Vaisala DRYCAP® HandHeld Dewpoint Meter DM70 is ideal for field checking DMT340 transmitters.



The DMT342 probe is installed using a flange or sampling cell. The small probe is ideal for integrating into larger equipment.

DMT342 with Small Size Flanged Probe

Pressure range	0 ... 50 bar / 0 ... 725 psia
Mechanical durability	up to 250 bar / 3625 psia
Probe diameter	12 mm / 0.5 inch
Installation	
Flange	36 mm / 1.4 inch
Sampling cell	HMP302SC

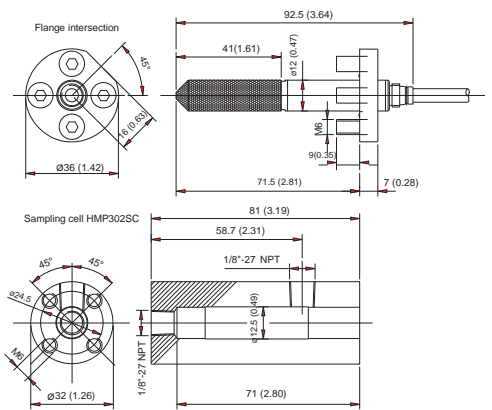

The DMT344 features a threaded connection for extended pressures with different fitting body options. It is ideal for permanent installations into pressurized or vacuum processes.

DMT344 with Probe for High Pressures

Pressure range	0 ... 50 bar / 0 ... 725 psia
Mechanical durability	up to 100 bar / 1450 psia
Probe diameter	12 mm / 0.5 inch
Installation	
Fitting Body	M22 x 1.5
Fitting Body	NPT 1/2"

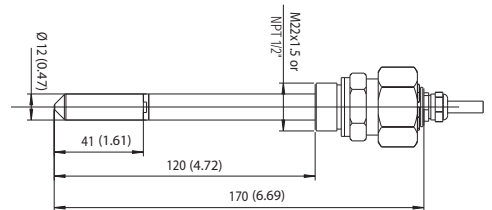

The DMT347 probe is ideal for tight spaces with thread connection. The small probe is installed using the threaded fitting bodies.

DMT347 with Small Sized Probe

Pressure range	0 ... 10 bar / 0 ... 145 psia
Mechanical durability	up to 10 bar / 145 psia
Probe diameter	12 mm / 0.5 inch
Installation	
Fitting Body	R 3/8" ISO
Fitting Body	G 1/2" ISO
Fitting Body	NPT 1/2"

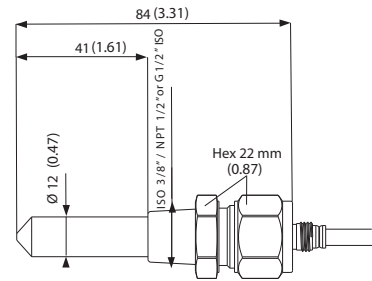

The DMT348 is ideal for installations in pressurized processes where the probe needs to be removed while the process is running. The probe depth is adjustable.

DMT348 with Probe for Pipeline Installations

Pressure range	0 ... 40 bar / 0 ... 580 psia
Adjustable length	41 ... 149/371 mm / 1.61 ... 5.87/14.6 inch
Installation	
Fitting Body	R1/2" ISO
Fitting Body	NPT 1/2"
Ball Valve Set	BALLVALVE-1
Sampling Cell	DMT 242SC or DMT242SC2

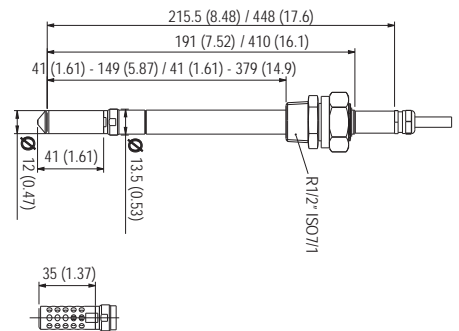

Optional filter for low pressures (for all models)

Technical Data

Measured parameters

Dewpoint

Sensor	Vaisala DRYCAP®180M
Measurement range	-70 ... +80 °C (-94 ... +176 °F) Td
For continuous use	-70 ... +45 °C (-94 ... +113 °F) Td
Accuracy	up to 20 bar/290 psia ±2 °C/±3.6 °F see the accuracy graph below
	20 ... 50 bar/290 ... 725 psia additional inaccuracy +1 °C Td

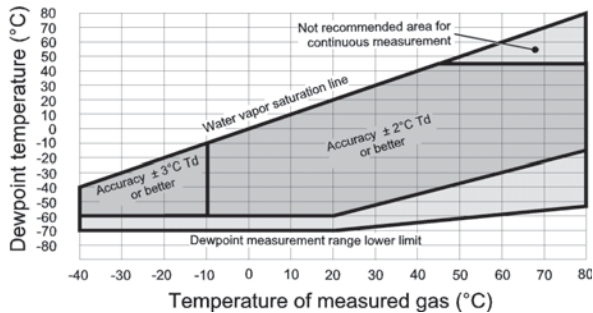

Dewpoint accuracy vs. measurement conditions

Response time	63% [90%] at +20°C gas temperature
Flow rate	1 l/min and 1 bar pressure
	-60 -> -20 °C Td (-76 -> -4 °F Td) 5s [10s]
	-20 -> -60 °C Td (-4 -> -76 °F Td) 45s [10min]

Temperature

Measurement range	0 ... +80 °C (32 ... +176 °F)
Accuracy	±0.2 °C at room temperature
Temperature sensor	Pt 100 IEC 751 1/3 class B

Relative humidity

Measurement range	0 ... 70 %RH
Accuracy (RH <10 %RH, at +20 °C)	±0.004 %RH + 20% of reading

ppm

Measurement range (typical)	10 ... 2500 ppm
Accuracy (at +20 °C, 1 bar)	1 ppm + 20% of reading
Other measurement parameters available (depends on model) mixing ratio, absolute humidity, pressure dewpoint calculated to 1 bar, temperature difference (T-Td), water vapor pressure	

Operating environment

Operating temperature	
for probes	-40 ... +80 °C (-40 ... +176 °F)
Mechanical durability	Up to +180 °C (+356 °F)
for transmitter body	-40 ... +60 °C (-40 ... +140 °F)
with display	0 ... +60 °C (32 ... +140 °F)
Storage temperature range	-55 ... +80 °C (-67 ... +176 °F)
Pressure range for probes	See probe specifications
Sample flow rate	No effect
Measured gases	non corrosive
Complies with EMC standard EN61326-1, Electrical equipment for measurement, control and laboratory use - EMC requirements; Industrial environment.	

Inputs and outputs

Operating voltage	10 ... 35 VDC, 24 VAC
with optional power supply module	100 ... 240 VAC 50/60 Hz
Power consumption @ 20 °C (U _{in} 24VDC)	
RS-232	max 25 mA
U _{out} 2 x 0...1V / 0...5V / 0...10V	max 25 mA
I _{out} 2 x 0...20 mA	max 60 mA
display and backlight	+ 20 mA
during sensor purge	+ 110 mA max
Analog outputs (2 standard, 3rd optional)	
current output	0 ... 20 mA, 4 ... 20 mA
voltage output	0 ... 1 V, 0 ... 5 V, 0 ... 10 V
Accuracy of analog outputs at 20 °C	0.05 % full scale
Temperature dependence of the analog outputs	± 0.005 %/°C full scale

External loads

current outputs	R _L < 500 ohm
0 ... 1V output	R _L > 2 kohm
0 ... 5V and 0 ... 10V outputs	R _L > 10 kohm
Max wire size	0.5 mm ² (AWG 20) stranded wires recommended
Digital outputs	RS-232, RS-485 (optional)
Service connection	RS-232, USB
Relay outputs	0.5 A, 250 VAC, SPDT (optional)
Ethernet interface (optional)	
Supported standards	10/100Base-T
Connector	RJ45
Protocols	Telnet
Software support	Vaisala MI70 link
WLAN interface (optional)	
Supported standard	802.11b
Antenna connector type	RP-SMA
Protocols	Telnet
Security	WEP 64/128, WPA
Software support	Vaisala MI70 link
Authentication / Encryption	
Open / no encryption	
Open / WEP	
WPA Pre shared key / TKIP	
WPA Pre shared key / CCMP (a.k.a. WPA2)	
Optional data logger with real-time clock	
Logged parameters	max. three with trend/min/max values
Logging interval	10 sec (fixed)
Max. logging period	4 years 5 months
Logged points	13.7 million points per parameter
Battery lifetime	min. 5 years
Display	LCD with backlight, graphic trend display of any parameter
Display menu languages	English, Chinese, Spanish, German, French, Japanese, Russian, Swedish, Finnish

Mechanics

Cable bushing	M20x1.5 for cable diameter 8 ... 11mm/0.31 ... 0.43"
Conduit fitting	1/2"NPT
User cable connector (optional)	M12 series 8 pin (male)
option 1	with plug (female) with 5 m / 16.4 ft black cable
option 2	with plug (female) with screw terminals
USB-RJ45 Serial Connection Cable	order no. 219685
Probe cable diameter	5.5 mm
Probe cable lengths	2 m, 5 m or 10 m
Housing material	G-ALSi 10 Mg (DIN 1725)
Housing classification	IP 65 (NEMA 4X)

Dimensions

Dimensions in mm (inches)

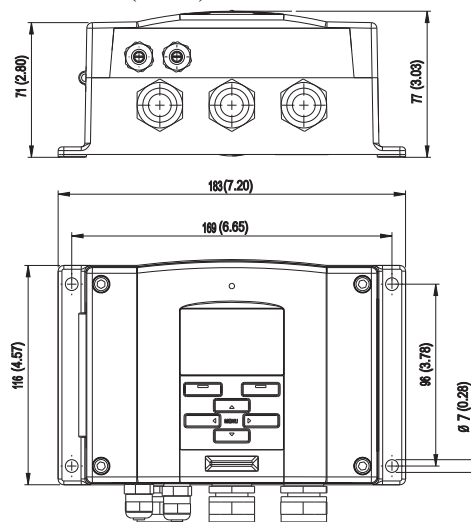

DRYCAP® is a registered trademark of Vaisala.
Specifications subject to change without prior notice.
©Vaisala Oyj

