

HM44 Concrete Humidity Measurement System



The Vaisala HUMICAP® Structural Humidity Measurement Kit HM44 provides an easy and reliable solution for humidity measurements in structural material.

Excess moisture in structures can cause problems and economical losses. In new construction, the tight time schedule may not allow enough time for structures to dry completely. Later, excess moisture can cause surface deterioration, room air impurities, and in severe cases – mold. These problems often lead to expensive repairs.

Moisture measurement saves time and money

Measuring the moisture ensures that the structure is dry enough before starting the next construction phase. Accurate moisture measurement optimizes the construction schedule and decreases the probability of future repairs while the project is under warranty and beyond. In renovations, accurate moisture measurement helps detect the actual source of the moisture and the scope of the damage.

Reliable bore-hole method

Measuring relative humidity in a structural material such as concrete is

a clear indication of whether the material is dry enough.

The Vaisala HUMICAP® Structural Humidity Measurement Kit HM44 is ideal for measuring humidity in concrete. First, a hole is bored at the required depth, cleaned out, and a plastic sleeve inserted. At this point, the probe can be pushed into the sleeve and sealed. The material at the bottom of the hole releases humidity into the space around the probe until equilibrium is reached. The Vaisala HUMICAP® Humidity Indicator HMI41 can then be connected to the probe cable and a reading taken. Alternatively, the sleeve can be plugged after insertion.

When the humidity in the hole has reached equilibrium, the probe is inserted and left to stabilize for a short time before a reading is taken. The supplied cover protects the probe on the construction site and against the effects of the ambient conditions.

Features/Benefits

- Meets the new ASTM standard

The Vaisala HUMICAP® Structural Humidity Measurement Kit HM44 is the ideal solution for measuring humidity in concrete. The HM44 includes the following parts:

- HMI41 Indicator with batteries
- HMP44 RH & T Probes
- Protective cover with lid, 3 pcs (19268HM)
- Rubber plugs, 12 pcs (19267HM)
- Plastic tube set, 12 pcs (19266HM)
- Carrying case
- NIST traceable (certificate included)

Accessories needed for wet concrete installations:

- Plastic tube set, 12 pcs (19266HM)
- Plastic flange set, 12 pcs (26529HM)
- Long rubber plug set, 12 pcs (25630HM)

Concrete dries unevenly and is usually drier on the surface. A surface measurement alone may give misleading information. The sleeve enables measurements to be made at the correct depth, thus giving a true picture of the humidity in the concrete.

Measures in fresh concrete

The HM44 also measures humidity in fresh concrete. The advantage being that you do not have to drill the concrete. The sleeves are easily and quickly installed in the fresh concrete. When floor heating elements/water tubing are used, the measurements can be done without breaking the pipes.

Meets the ASTM standard

Both methods, drilling into hardened concrete and pre-installation into wet concrete, meet the new ASTM standard, "F2170-02 Standard Test Method for Determining Relative Humidity in concrete Floor Slabs Using in situ probes."

Technical Data

HMP44 probe

Relative humidity

Measurement range	0...100 %RH
Accuracy	
0...90 %RH	±2 %RH
90...100 %RH	±3 %RH
Typical long-term stability in air	better than 1 %RH/year
Response time (90%) at +20 °C in still air	15s

Typical response time when the concrete and the probe are in the same temperature (stabilized hole) 30 min
Humidity sensor HUMICAP® 180

Temperature

Measurement range	-20...+60 °C (-40...+140 °F)
Accuracy at +20 °C	±0.4 °C (±0.72 °F)
Temperature sensor	Pt 1000 IEC 751 1/3 Class B

General

Operating temperature range for electronics	-40...+60 °C (-40...+140 °F)
Sensor diameter	12 mm
Cable length	0.3 m
Probe length	69 mm
Housing material	ABS plastic
Housing classification	IP65
Sensor protection	membrane filter 17039HM
Bore hole diameter	16 mm
Measurement depth	min. 30 mm, max. 90 mm

HMI41 indicator

Maximum error caused by the indicator at +20 °C (+68 °F)	
humidity	±0.1 %RH
temperature	±0.1 °C (±0.18 °F)
Calculated quantities	dewpoint temperature, absolute humidity, wet bulb temperature, mixing ratio
Resolution	0.1 %RH/0.1 °C (0.1 °F)
Power supply	4 batteries, type IEC LR 6
Battery operation time (alkaline batteries)	72 h continuous use
Operating temperature range	-20...+60 °C (-4...+140 °F)
Operating humidity range non-condensing	0...100 %RH
Storage temperature range	-40...+70 °C -40...+158 °F
Display	two line LCD
Housing material	ABS plastic
Housing classification	IP53 (with connectors blocked)
Weight (incl. batteries)	300 g

General

Other probes to be used with the HMI41 indicator for the measurement of humidity in materials:

HMP42	23.5 cm probe, diameter 4 mm
HMP44L	as HMP44 but with a 2.7 meter cable
HMP46	320 mm tube of stainless steel, diameter 12 mm

Complies with EMC standard EN61326-1:1997 + Am1:1998 + Am2:2001; Portable Equipment.

Accessories needed for wet concrete installations:

Plastic tube set, 12 pcs.	19266HM
Plastic flange set, 12 pcs.	26529HM
Long rubber plug set, 12 pcs.	26530HM

Installation of the HM44 kit

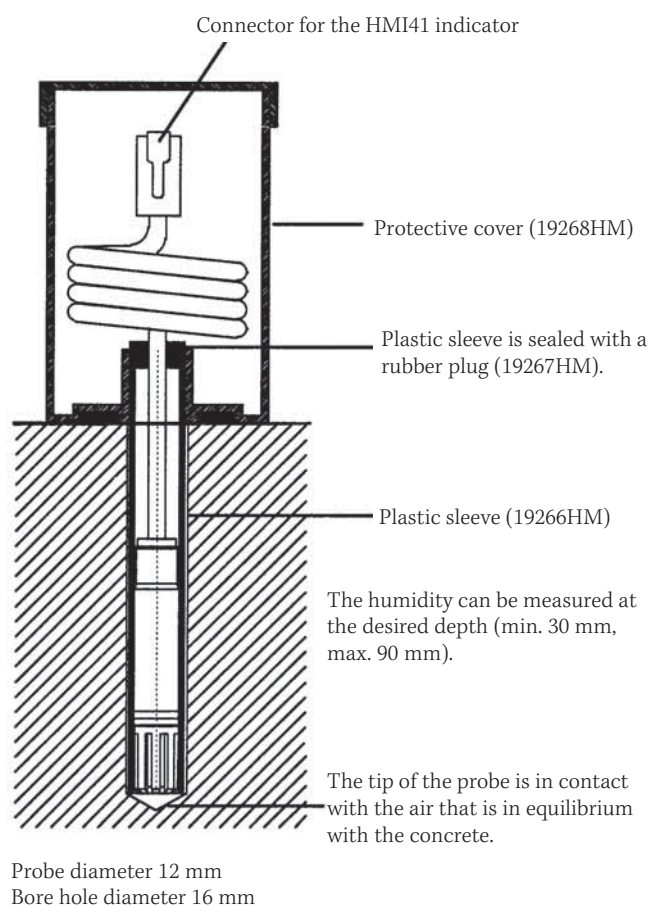

HUMICAP® is a registered trademark of Vaisala.
Specifications subject to change without prior notice.
© Vaisala Oyj

